

# 213D REMOVABLE BEZEL U-CLAMP PANEL MOUNT



Dry yet fillable gauge with removable bezel, adjustable pointer  
Stainless steel case and bezel, copper alloy internals

2

## SPECIFICATIONS

<b>Dial</b>	2 1/2" (63 mm)
<b>Case</b>	Stainless steel, dry yet fillable
<b>Wetted Parts</b>	Copper alloy
<b>Bezel</b>	Removable, stainless steel
<b>Lens</b>	Glass
<b>Pointer</b>	Adjustable, black aluminum
<b>Connection</b>	Center back mount with u-clamp 2 1/2" dial = 1/4" NPT
<b>Scale</b>	Standard: psi/BAR (x 100 = kPa)
<b>Accuracy</b>	2-1-2% of span ASME B40.1 Grade A
<b>Ambient Temp</b>	Dry = -30° F to 180° F Glycerine Filled = 30° F to 160° F



Design meets or exceeds ASME B40.100 pressure gauge standard.

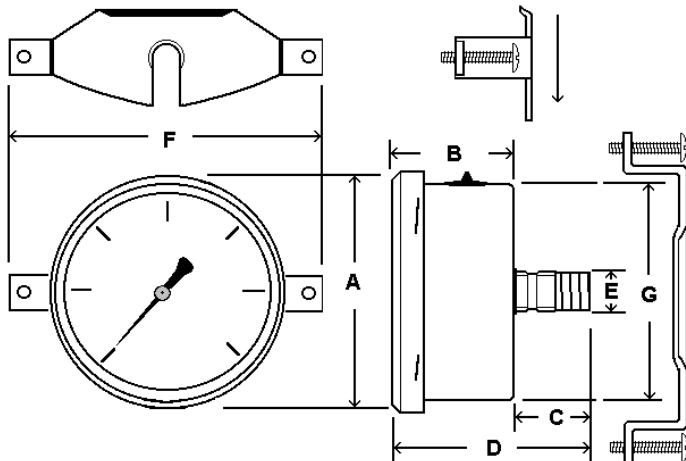

## AVAILABLE OPTIONS\*

- Certificate of Accuracy, NIST traceable
- Custom Dial
- Liquid Fill Options, see page 173
- Anti-Vibration Movement, see page 107
- Cleaned for Oxygen Service (dry only)
- Special Connection Size
- Plastic Lens
- Max/Min Pointer, see page 120

\*Lead times/minimums may apply

Dial	Unit	A	B	C	D	E	F	G
2 1/2"	In.	2.83"	1.37"	1.00"	2.29"	1/4"	3.84"	2.48"
	mm	72	35	25	58	NPT	98	63

## APPROXIMATE SHIPPING WEIGHTS/ BOX QUANTITIES

Dial Size	Est. Unit Weight	Box Qty
2 1/2"	0.55 lbs (0.25 kg)	50

NOTE: Because of continuing improvements, increments/specifications are subject to change without notice. Stock ranges vary by dial size and configuration. Consult PIC Gauges for availability.