

# 4001 9/16" HIGH PRESSURE CONNECTION



Heavy duty, all stainless steel gauge with removable bezel, adjustable pointer  
 1% accuracy, welded case-to-stem connection, dry yet fillable  
 9/16" HPM connection, Ranges 10,000 psi, 15,000 psi, 20,000 psi, 30,000 psi

## SPECIFICATIONS

<b>Dial</b>	4" (100 mm)
<b>Case</b>	Stainless steel, dry yet fillable Welded case-to-stem connection
<b>Wetted Parts</b>	316 stainless steel
<b>Movement</b>	With overload/underload stops
<b>Bezel</b>	Removable, stainless steel,
<b>Lens</b>	Laminated safety glass
<b>Pointer</b>	Adjustable, black aluminum
<b>Connection</b>	Lower mount 9/16-18" High Pressure Male
<b>Scale</b>	Standard: single scale psi
<b>Accuracy</b>	1% of span ASME B40.1 Grade 1A
<b>Ambient Temp</b>	Dry = -30° F to 180° F Glycerine Filled = 30° F to 160° F

*Design meets or exceeds ASME B40.100 pressure gauge standard.*

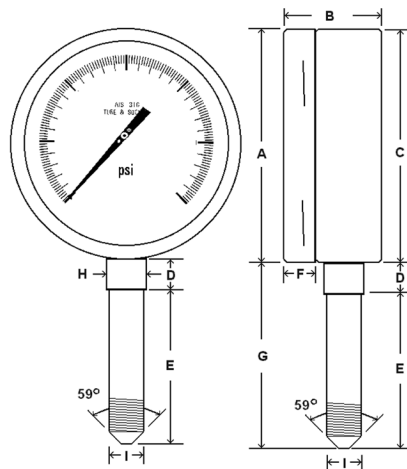

Dial	Unit	A	B	C	D	E	F	G	H	Thread
4"	In.	4.00"	1.97"	3.87"	0.81"	2.45"	0.66"	3.26"	0.68"	9/16-18
	mm	100	50	99	21	62	17	83	17	MP Male

## AVAILABLE OPTIONS\*

- Certificate of Accuracy, NIST traceable
- Custom Dial
- Liquid Fill Options, see page 173
- Cleaned for Oxygen Service (dry only)
- Knife-edge pointer
- Protective Rubber Cover, see page 119
- With Gland/Collar
- Max/Min Pointer, see page 120
- 0.5% Accuracy Available

\*Lead times/minimums may apply

## APPROXIMATE SHIPPING WEIGHTS/BOX QUANTITIES

Dial Size	Est. Unit Wt.	Box Qty
4"	1.20 lbs (0.54 kg)	15

## STANDARD DIAL CONFIGURATIONS FOR 4001 9/16" SERIES

Part Number	Dial Range	Figure Intervals	Graduation Intervals
4001-9LU	0/10,000 psi	1,000 psi	100 psi
4001-9LV	0/15,000 psi	3,000 psi	100 psi
4001-9LW	0/20,000 psi	2,000 psi	200 psi
4001-9LX	0/30,000 psi	6,000 psi	200 psi



**COLLAR**



**GLAND**

Part Number	Description
60-2H9	Collar
60-2HM9	Gland

**SOLD SEPARATELY**

NOTE: Because of continuing improvements, specifications are subject to change without notice. Stock ranges vary by dial size and configuration. Consult PIC Gauges for availability.