

# 6004 6" ALL STAINLESS FRONT FLANGE PANEL MOUNT



Heavy duty, all stainless steel gauge with removable bezel, adjustable pointer  
1% accuracy, welded case-to-stem connection, dry yet fillable

## SPECIFICATIONS

<b>Dial</b>	6" (150 mm)
<b>Case</b>	Stainless steel, dry yet fillable Welded case-to-stem connection
<b>Wetted Parts</b>	316 stainless steel
<b>Movement</b>	With overload/underload stops
<b>Bezel</b>	Removable, stainless steel
<b>Lens</b>	Laminated safety glass
<b>Pointer</b>	Micro adjustable, black aluminum
<b>Connection</b>	Lower back mount with front flange 1/4" NPT
<b>Scale</b>	Standard: single scale psi
<b>Accuracy</b>	1% of span ASME B40.1 Grade 1A
<b>Ambient Temp</b>	Dry = -30° F to 180° F Glycerine Filled = 30° F to 160° F



4

Design meets or exceeds ASME B40.100 pressure gauge standard.

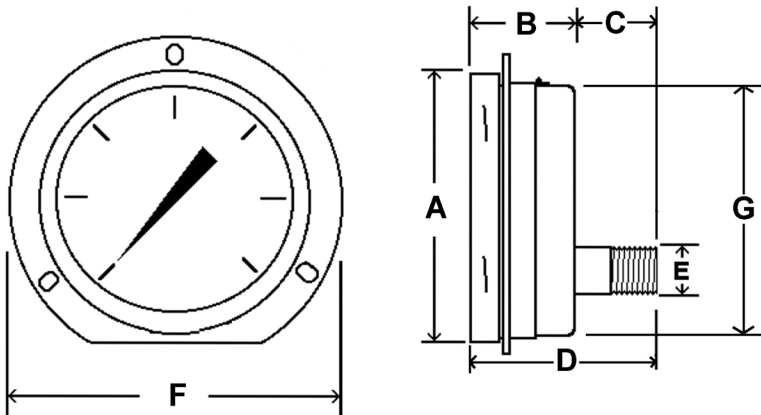

## AVAILABLE OPTIONS\*

- Certificate of Accuracy, NIST traceable
- Custom Dial
- Liquid Fill Options, see page 173
- Special Connection Size
- Cleaned for Oxygen Service (dry only)
- Polycarbonate Lens
- 1/2" NPT or Custom Connections

\*Lead times/minimums may apply

## APPROXIMATE SHIPPING WEIGHTS/ BOX QUANTITIES

Dial	Unit	A	B	C	D	E	F	G
6"	In.	6.76"	2.02"	1.35"	3.37"	1/4" or 1/2"	7.65"	6.24"
	mm	172	52	34	86	NPT	194	158

Dial Size	Est. Unit Wt.	Box Qty
6"	2.30 lbs (1.06 kg)	5

For complete flange dimensions, see page 121.

NOTE: Because of continuing improvements, increments/specifications are subject to change without notice. Stock ranges vary by dial size and configuration. Consult PIC Gauges for availability.