



6009 6" ALL STAINLESS BACK FLANGE

Heavy duty, all stainless steel gauge with removable bezel, adjustable pointer
 1% accuracy, welded case-to-stem connection, dry yet fillable

SPECIFICATIONS

Dial	6" (150 mm)
Case	Stainless steel, dry yet fillable Welded case-to-stem connection
Wetted Parts	316 stainless steel
Movement	With overload/underload stops
Bezel	Removable, stainless steel
Lens	Laminated safety glass
Pointer	Micro adjustable, black aluminum
Connection	Lower back mount with back flange 1/4" NPT standard 1/2" NPT available (limited ranges)
Scale	Standard: single scale psi
Accuracy	1% of span ASME B40.1 Grade 1A
Ambient Temp	Dry = -30° F to 180° F Glycerine Filled = 30° F to 160° F

4

Design meets or exceeds ASME B40.100 pressure gauge standard.



AVAILABLE OPTIONS*

- Certificate of Accuracy, NIST traceable
- Custom Dial
- Liquid Fill Options, see page 173
- Special Connection Size
- Cleaned for Oxygen Service (dry only)
- Polycarbonate Lens

*Lead times/minimums may apply

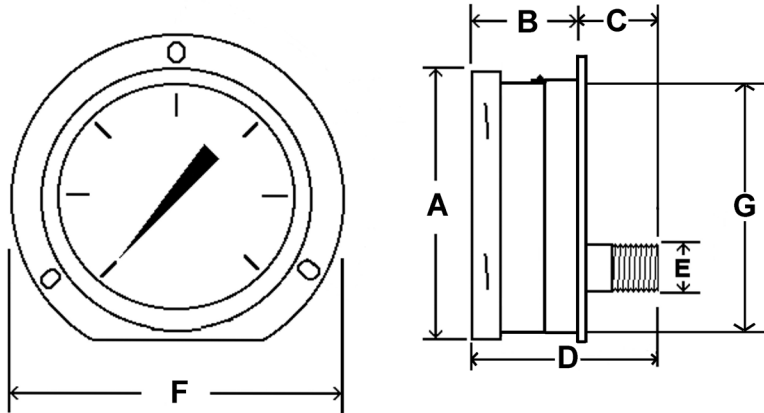

APPROXIMATE SHIPPING WEIGHTS/ BOX QUANTITIES

Dial	Unit	A	B	C	D	E	F	G
6"	In.	6.76"	2.02"	1.50"	3.54"	1/4" or 1/2"	7.63"	6.24"
	mm	172	52	38	90	NPT	194	158

Dial Size	Est. Unit Wt.	Box Qty
6"	4.65 lbs (2.10 kg)	upon request

For complete flange dimensions, see page 121.

NOTE: Because of continuing improvements, increments/specifications are subject to change without notice. Stock ranges vary by dial size and configuration. Consult PIC Gauges for availability.