

LP3-SB LOW PRESSURE STAINLESS STEEL CASE



Capsule type pressure gauge for accurate measurement of low pressures
Suitable for air, water, oil, gas or any other media not corrosive to Copper alloy

SPECIFICATIONS

Dial	2 1/2" (63 mm)
Case	Stainless steel, dry non-fillable
Wetted Parts	Copper alloy
Bezel	Removable, stainless steel
Lens	Heavy duty glass
Pointer	Adjustable, black aluminum Adjustment screw on dial face
Connection	Center back mount with u-clamp 1/4" NPT
Scale	Standard: single scale inches of water column or psi
Accuracy	2-1-2% of span on 2 1/2" ASME B40.1 Grade A
Ambient Temp	-30° F to 180° F

Design meets or exceeds ASME B40.100 pressure gauge standard.

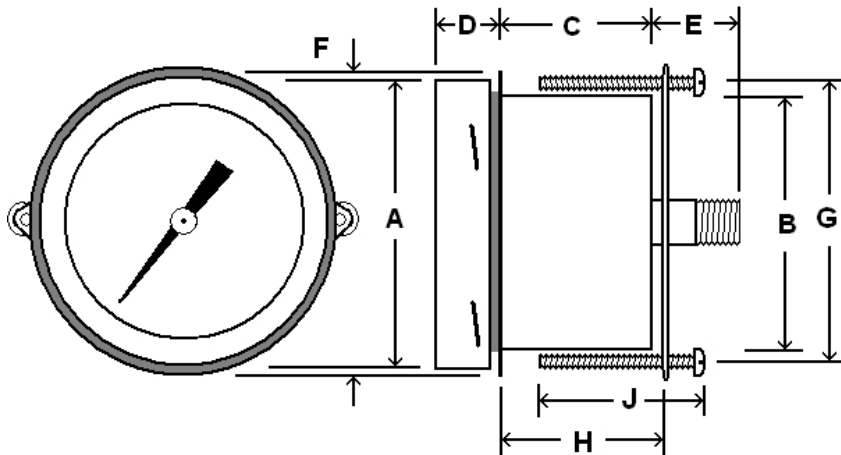

Dial	Unit	A	B	C	D	Conn.	E
2 1/2"	In.	2.95"	2.56"	1.33"	0.55"	1/4" NPT	1.10"
	mm	75	65	34	14		28

Dial	Unit	F	G	H	J
2 1/2"	In.	3.22"	2.83"	1.46"	1.46"
	mm	82	72	37	37

AVAILABLE OPTIONS*

- Certificate of Accuracy, NIST Traceable
- Custom Dial
- Special Connection Size
- Other Lens Material
- Cleaned for Oxygen Service
- Dual Scale

*Lead times/minimums may apply

APPROXIMATE SHIPPING WEIGHTS/ BOX QUANTITIES

Dial Size	Est. Unit Wt.	Box Qty
2 1/2"	0.65 lbs (0.30 kg)	upon request

NOTE: Because of continuing improvements, increments/specifications are subject to change without notice. Stock ranges vary by dial size and configuration. Consult PIC Gauges for availability.