



LP4 LOW PRESSURE FRONT FLANGE PANEL MOUNT

Capsule type pressure gauge for accurate measurement of low pressures
 Suitable for air, water, oil, gas or any other media not corrosive to copper alloy

SPECIFICATIONS

Dial	2 1/2" (63 mm)
Case	Chrome plated steel, dry non-fillable
Wetted Parts	Copper alloy
Lens	Plastic, removable twist lock
Pointer	Adjustable, black aluminum Adjustment screw at rear of case
Connection	Center back mount with front flange 1/4" NPT
Scale	Standard: single scale inches of water column or psi
Accuracy	3-2-3% of span ASME B40.1 Grade B
Ambient Temp	-30° F to 180° F

Design meets or exceeds ASME B40.100 pressure gauge standard.



AVAILABLE OPTIONS*

- Certificate of Accuracy, NIST Traceable
- Custom Dial
- Special Connection Size
- Cleaned for Oxygen Service
- Dual Scale

*Lead times/minimums may apply

5

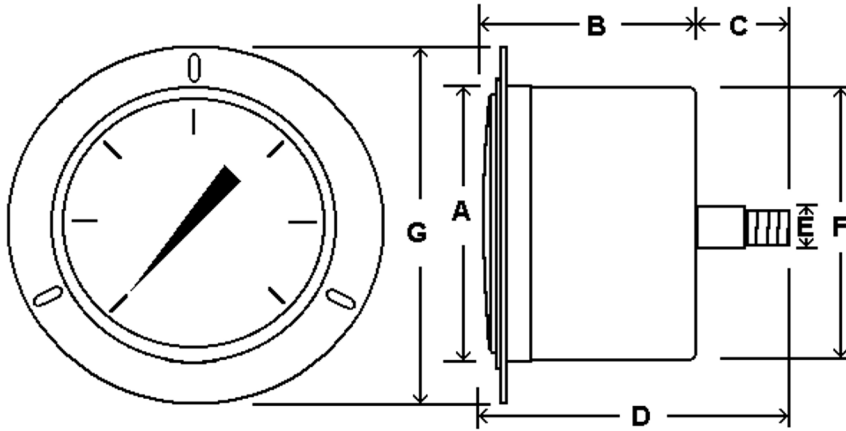

Dial	Unit	A	B	C	D	E	F	G
2 1/2"	In.	2.71"	1.81"	0.92"	2.72"	1/4" NPT	2.60"	3.44"
	mm	69	46	23	70		66	87

APPROXIMATE SHIPPING WEIGHTS/ BOX QUANTITIES

Dial Size	Est. Unit Wt.	Box Qty
2 1/2"	0.55 lbs (0.26 kg)	upon request

NOTE: Because of continuing improvements, increments/specifications are subject to change without notice. Stock ranges vary by dial size and configuration. Consult PIC Gauges for availability.