

LOW PRESSURE TEST KIT



Low pressure test kit for accurate measurement of LP or natural gas
Includes black ABS plastic molded case, hose and fitting for portable testing

SPECIFICATIONS

Part Number	TEST KIT-LP
Dial	2 1/2" (63 mm)
Case	Black painted steel, dry non-fillable
Wetted Parts	Copper alloy
Range	0/20 oz X 0/35" wc*
Lens	Plastic, removable twist lock
Pointer	Adjustable, black aluminum Adjustment screw at rear of case
Connection	Gauge = Copper alloy hose barb Hose = Flexible rubber adapter fits multiple pipe sizes from 1/4" to 5/8" OD
Scale	Standard: dual scale inches of water column and oz/in ²
Accuracy	2% of span ASME B40.1 Grade B
Ambient Temp	-30° F to 180° F
Hose Tube	3 feet (91 cm) rubber

Design meets or exceeds ASME B40.100 pressure gauge standard.

For gauge dimensions, see page 67.

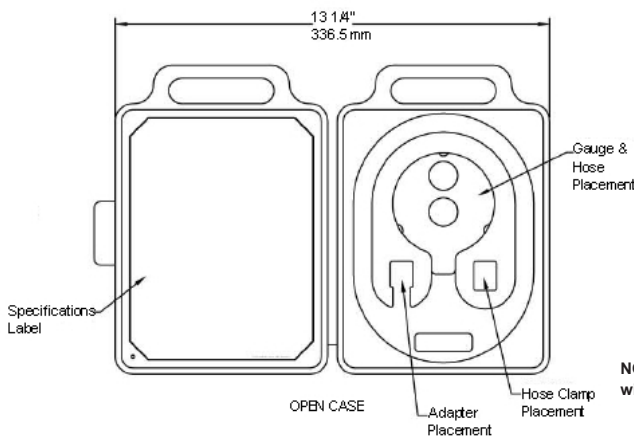
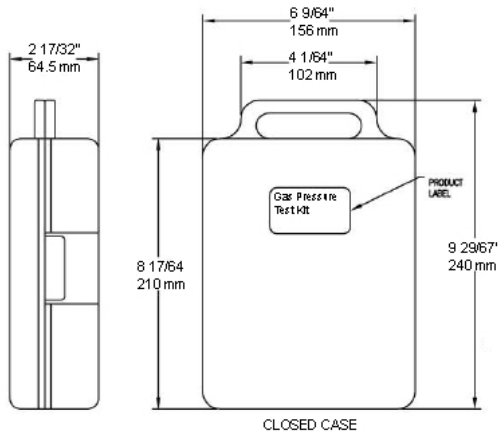

AVAILABLE OPTIONS*

- Certificate of Accuracy, NIST Traceable
- Custom Dial
- Special Connection Size
- Cleaned for Oxygen Service
- Alternate Pressure/Vacuum Ranges

*Lead times/minimums may apply

APPROXIMATE SHIPPING WEIGHTS/ BOX QUANTITIES

Dial Size	Est. Unit Wt.	Box Qty
2 1/2"	1.50 lbs (0.68 kg)	upon request

NOTE: Because of continuing improvements, increments/specifications are subject to change without notice. Stock ranges vary by dial size and configuration. Consult PIC Gauges for availability.