

“UV” Steam-ASME Section VIII Pressure Vessels

Model	SVI
Sizes	1½", 2", 2½", 3", 4", 6"
Connections	NPT, FLG
Body Material	Cast Iron
PMO Max. Operating Pressure	250 PSIG (Steam)
TMO Max. Operating Temperature	422° F

Typical Applications

The **SVI** Safety Valves are used for over-pressure protection on unfired pressure vessels in saturated steam systems. Valves are 100% factory tested and made in the USA.

How It Works

In the event steam pressure increases to the set point, the safety valve will “pop open” discharging steam faster than it can be produced; allowing system pressure to return to safe levels at which point the valve will close.

Features

- Stainless Steel wetted trim nozzle & disc
- Metal to metal seating, lapped to optimum flatness
- Tapped body drain allows piping of condensate away from valve to protect the internals from fouling
- Two control rings assure maximum performance and adjustability

Sample Specification

Safety valves shall be high capacity design with cast iron construction featuring rust-proof stainless steel stems, springs, washers and metal-to-metal lapped seats. Units shall be qualified to the ASME Boiler Code Section VIII and suitable for steam service.

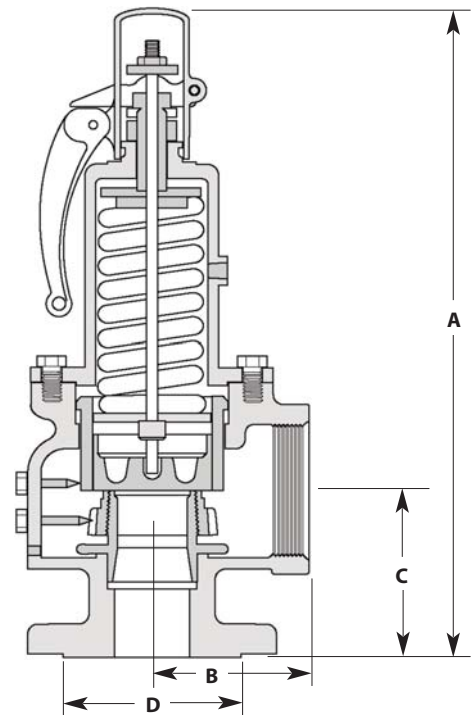

DIMENSIONS & WEIGHTS – inches

Model Code	Valve Size Inlet x Outlet	Orifice Size	A	B	C	Hex Flat D	Weight (lbs)
SVI-16F-18S-J	1½" 250#FLG x 2½" FNPT	J	15	4	4.31		35
SVI-17F-19S-K	2" 250#FLG x 3" FNPT	K	16	4	4.63		36
SVI-17S-19S-K	2" FNPT x 3" FNPT	K	16	4	4.63	3.75	37
SVI-18F-19S-K	2½" 250#FLG x 3" FNPT	K	16	4	4.63		41
SVI-19F-19S-K	3" 250#FLG x 3" FNPT	K	16	4	4.63		45
SVI-18F-20S-L	2½" 250#FLG x 4" FNPT	L	22	5.13	5.63		84
SVI-18S-20S-L	2½" FNPT x 4" FNPT	L	22	5.13	5.63	5.38	81
SVI-19F-20S-L	3" 250#FLG x 4" FNPT	L	22	5.13	5.63		85
SVI-20F-20S-L	4" 250#FLG x 4" FNPT	L	22	5.13	5.63		90
SVI-19S-20S-M	3" FNPT x 4" FNPT	M	22	5.13	5.63	5.38	80
SVI-19F-20S-M	3" 250#FLG x 4" FNPT	M	22	5.13	5.63		87
SVI-20F-20S-M	4" 250#FLG x 4" FNPT	M	22	5.13	5.63		95
SVI-20F-22F-N	4" 250#FLG x 6" 125#FLG	N	28	7.25	6.75		210
SVI-20F-22F-P	4" 250#FLG x 6" 125#FLG	P	28	7.25	6.75		215
SVI-22F-23F-Q	6" 250#FLG x 8" 125#FLG	Q	42	10	9.25		530
SVI-22F-23F-R	6" 250#FLG x 8" 125#FLG	R	42	10	9.25		530

MATERIALS

Body	Cast Iron
Guide Ring	Brass
Disc	Stainless Steel
Stem	Stainless Steel

"UV" Steam-ASME Section VIII Pressure Vessels

CAPACITIES – Pounds of saturated steam per hour (lbs/hr)								
Set Pressure (PSIG)	Orifice Letter / Area in Square Inches							
	"J" = 1.358	"K" = 1.926	"L" = 2.990	"M" = 3.774	"N" = 4.550	"P" = 6.692	"Q" = 11.593	"R" = 16.798
15	2008	2848	4421	5580	6728	9895	17141	24820
20	2315	3283	5097	6433	7756	11408	19762	28615
25	2622	3719	5773	7287	8785	12921	22383	32410
30	2929	4154	6449	8140	9814	14434	25004	36205
35	3267	4633	7193	9079	10945	16098	27887	40379
40	3604	5112	7936	10017	12077	17762	30771	44554
45	3942	5591	8680	10956	13208	19426	33654	48729
50	4280	6070	9423	11894	14340	21091	36537	52903
55	4618	6549	10167	12833	15471	22755	39420	57078
60	4955	7028	10911	13771	16603	24419	42303	61252
65	5293	7507	11654	14710	17735	26083	45186	65427
70	5631	7986	12398	15649	18866	27748	48069	69601
75	5969	8465	13141	16587	19998	29412	50952	73776
80	6306	8944	13885	17526	21129	31076	53835	77951
85	6644	9423	14629	18464	22261	32740	56719	82125
90	6982	9902	15372	19403	23392	34405	59602	86300
95	7319	10381	16116	20341	24524	36069	62485	90474
100	7657	10860	16859	21280	25655	37733	65368	94649
105	7995	11339	17603	22218	26787	39397	68251	98823
110	8333	11818	18346	23157	27919	41062	71134	102998
115	8670	12297	19090	24096	29050	42726	74017	107173
120	9008	12776	19834	25034	30182	44390	76900	111347
125	9346	13255	20577	25973	31313	46055	79783	115522
130	9684	13734	21321	26911	32445	47719	82666	119696
135	10021	14213	22064	27850	33576	49383	85550	123871
140	10359	14692	22808	28788	34708	51047	88433	128045
145	10697	15171	23552	29727	35839	52712	91316	132220
150	11034	15650	24295	30666	36971	54376	94199	136395
155	11372	16129	25039	31604	38103	56040	97082	140569
160	11710	16608	25782	32543	39234	57704	99965	144744
165	12048	17087	26526	33481	40366	59369	102848	148918
170	12385	17566	27270	34420	41497	61033	105731	153093
175	12723	18045	28013	35358	42629	62697	108614	157267
180	13061	18524	28757	36297	43760	64361	111497	161442
185	13399	19003	29500	37236	44892	66026	114381	165617
190	13736	19482	30244	38174	46023	67690	117264	169791
195	14074	19961	30988	39113	47155	69354	120147	173966
200	14412	20440	31731	40051	48287	71018	123030	178140
205	14749	20919	32475	40990	49418	72683	125913	182315
210	15087	21398	33218	41928	50550	74347	128796	186489
215	15425	21876	33962	42867	51681	76011	131679	190664
220	15763	22355	34706	43806	52813	77675	134562	194839
225	16100	22834	35449	44744	53944	79340	137445	199013
230	16438	23313	36193	45683	55076	81004	140329	203188
235	16776	23792	36936	46621	56207	82668	143212	207362
240	17113	24271	37680	47560	57339	84332	146095	211537
245	17451	24750	38424	48498	58471	85997	148978	215711
250	17789	25229	39167	49437	59602	87661	151861	219886
Approx. 1 PSI incr.	68	96	149	188	226	333	577	835

Notes: 1) Ratings are 90% of actual capacity. 2) For Set Pressures over 250 PSIG, consult factory. 3) For other sizes, consult factory.
4) ASME Section I – Steam Boilers – pounds of saturated steam per hour @ 3% or 2 PSIG accumulation (whichever is greater).
5) ASME Section VIII – Pressure Vessels – pounds of saturated steam per hour @ 10 % or 3 PSIG accumulation (whichever is greater).

PIPELINE ACCESSORIES