

Westwood

CAST IRON TOP FUEL FILTERS

WITH **EPOXY** COATING INSIDE!

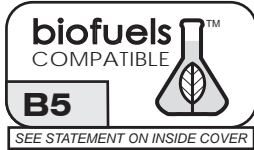

- Exact Replacement for popular CAST IRON top filters
- Heavy gauge canister with EPOXY COATING on the inside - FIRST in the industry!
- UL GPH and pressure ratings EXCEED comparable OEM filters
- 360° screwdriver slot makes disassembly for element changing easy
- Service environment: Indoors, 20° to 105° F





CHOICE OF ELEMENT INSIDE

Pure-Oil™

Fiber-Welded White Element



No. **F20**

CLASSIC **FELT™**

Stacked Segment Element

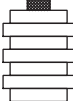

No. **F25**



CHOICE OF ELEMENT INSIDE

Pure-Oil™

Fiber-Welded White Element



No. **F65**

CLASSIC **FELT™**

Stacked Segment Element



No. **F70**

COMPLETE CAST IRON TOP FILTERS with EPOXY coated canister

<input checked="" type="checkbox"/> No.	Element Type	GPH	PSI	Exact Replacement for:
F20	Pure-Oil™	17	52	General 1A-25A
F25	CLASSIC FELT™			
F65	Pure-Oil™	32	52	General 2A-700A
F70	CLASSIC FELT™			

All filters have 3/8"- NPT pipe connections

 Take a look ...

UL Recognized CANISTER UPGRADE KITS on page F12
Individual FILTER GASKETS on page F11

Westwood

HIGH CAPACITY CAST IRON TOP FUEL FILTERS

WITH **EPOXY** COATING INSIDE!

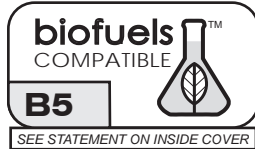

- Exact Replacement for popular CAST IRON top filters
- Heavy gauge canister with EPOXY COATING on the inside - FIRST in the industry!
- UL GPH and pressure ratings EXCEED comparable OEM filters
- 360° screwdriver slot makes disassembly for element changing easy
- **BIG GUY™** element holds twice as much as standard elements
- Service environment: Indoors, 20° to 105° F



ELEMENT INSIDE

Pure-Oil™

Fiber-Welded White Element



BIG GUY™
ELEMENT

No. **F80**



ELEMENT INSIDE

CLASSIC *YARN™*

Honeycomb Wound Element



No. **F84**

COMPLETE CAST IRON TOP FILTERS with EPOXY coated canister

BIG GUY™
ELEMENT

HOLDS TWICE AS MUCH!

<input checked="" type="checkbox"/> No.	Element Type	GPH	PSI	Exact Replacement for:
F80	Pure-Oil™ BIG GUY™	30	52	Fulflo FB4
F84	CLASSIC YARN™	22	52	

All filters have 3/8"- NPT pipe connections

 Take a look . . .

UL Recognized CANISTER UPGRADE KITS on page F12
Individual FILTER GASKETS on page F11

Please order by No.

Westwood

the NEW industry leader in Spin-Ons!

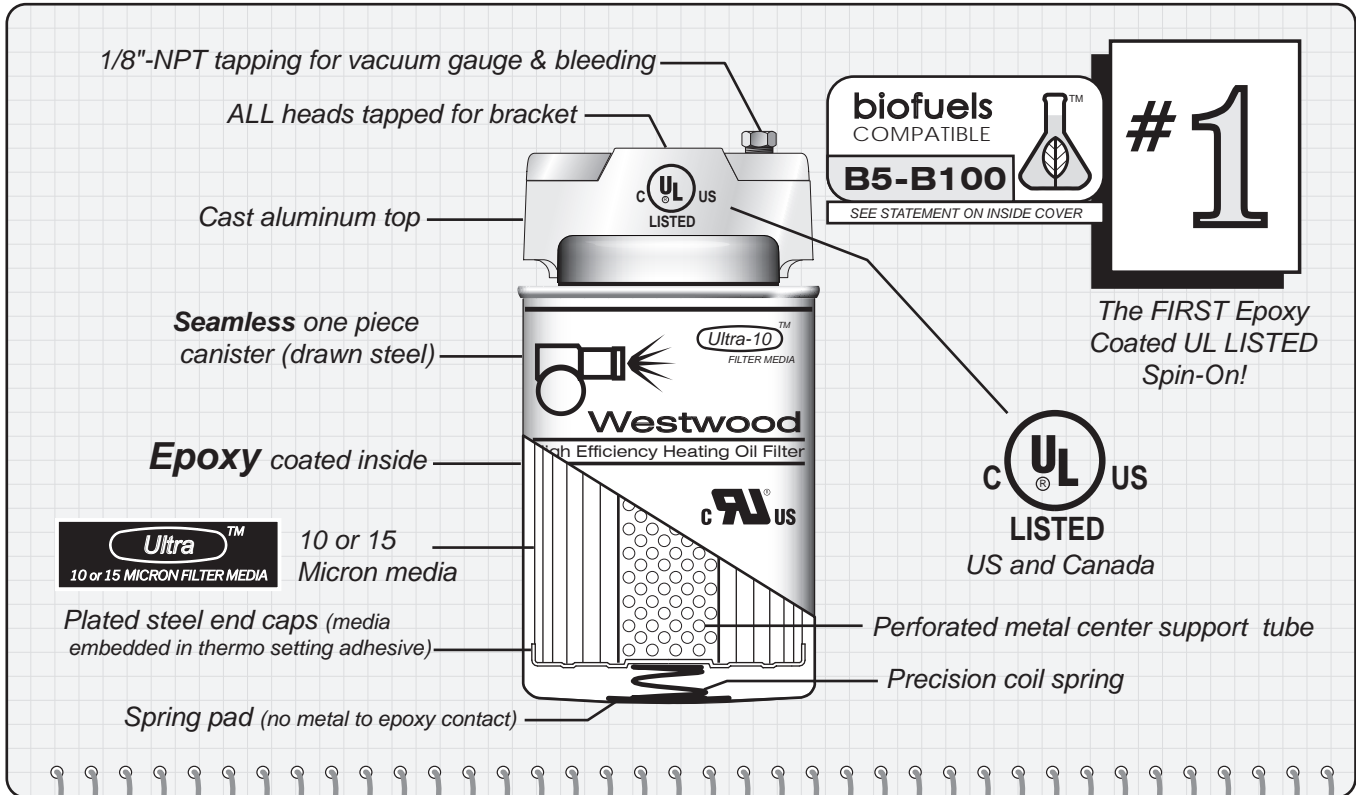

biofuels
COMPATIBLE
B5-B100
SEE STATEMENT ON INSIDE COVER

#1

The **FIRST** Epoxy Coated UL LISTED Spin-On!

UL LISTED
US and Canada

For Every Service Need...

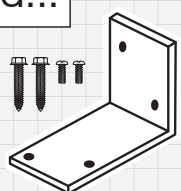
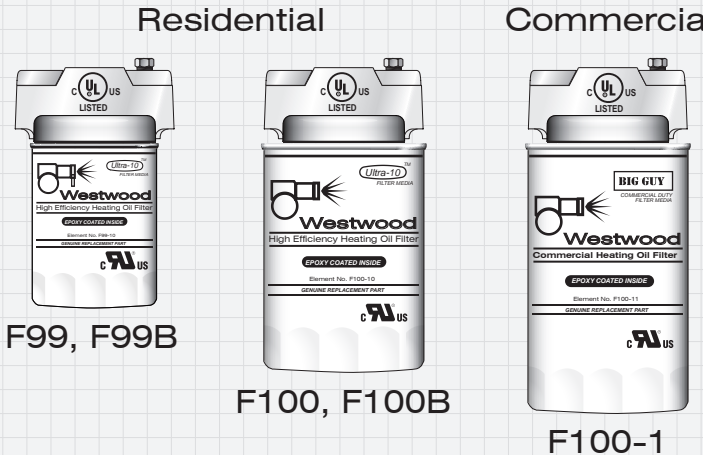

Mounting Bracket Kit

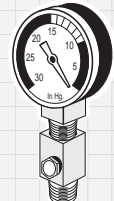

FLI™
Filter Life Indicator with Gauge Mount & Bleeder fitting

See the following pages for a complete listing of the entire Spin-On line, replacement elements, and accessories.

Model no.	F99	F99B	F100	F100B	F100-1
Microns	10	15	10	15	30
GPH	16	16	29	29	52
Fuel Oils	1, 2, up to B5	1, 2, up to B100	1, 2, up to B5	1, 2, up to B100	1, 2, up to B5

All Westwood Spin-On filters and replacement elements are either UL Listed or UL Recognized Components

THE NEW F99-2 SPIN-ON FILTER

Now The Perfect Size!

IF YOU LIKE
THIS FILTER...

...YOU'RE GONNA LOVE
THIS FILTER!



F20

- 17 GPH
- 52 PSI MAX
- UL Listed
- Epoxy Coated



F99-2

- 16 GPH
- 47 PSI MAX
- UL Listed
- Epoxy Coated
- 10 Micron Filtration
- Mounting Bracket
- Quick & Clean Filter Change
- Fits In Same Space As Traditional Filters

The New F99-2 Spin-on filter

Designed to match the size and performance of traditional oil burner filters, but with improvements that you will love! The F99-2 gives you 10 micron filtration, quick and clean filter changes, a mounting bracket, in a size that fits in the same space as traditional filters.

P/N	Description
F99-2	Complete Spin-on Filter w/mounting bracket
F99-10	Replacement Cartridge Only



Please order by  No.

F4

All Spin-On filters have 3/8"-NPT pipe connections and a 1/8"-NPT bleeder/gauge port. Service environment: Indoors, 20° to 105° F.

biofuels
COMPATIBLE

B5-B100



SEE STATEMENT ON INSIDE COVER

RESIDENTIAL - 16 GPH, 40 PSI, 10 or 15 Micron



Traditional
F20

New!
F99-2
F99-2B

The New F99-2 & F99-2B Spin-on filters

Designed to match the size and performance of traditional oil burner filters, but with improvements that you will love! The F99-2 & F99-2B (biofuel) filters give you 10 & 15 micron filtration respectively. They offer quick and clean filter changes, a mounting bracket, in a size that fits in the same space as traditional filters.



No. **F99-2**
 No. **F99-2B**
Complete Filter with
bracket kit



No. **F99-10**
 No. **F99-10B**
Replacement Element,
individ. boxed with "O" ring

Part No.	F99-2	F99-2B	F99-10	F99-10B
Microns	10	15	10	15
GPH	16	16	16	16
Fuel Oils	1, 2, up to B5	1, 2, up to B100	1, 2, up to B5	1, 2, up to B100

RESIDENTIAL - 29 GPH, 40 PSI, 10 or 15 Micron



No. **F100**
Complete Filter



No. **F100-2**
 No. **F100-2B**
Complete Filter with
bracket kit



No. **F100-4**
Complete Filter with
bleeder fitting and **FLI**[™]
gauge



No. **F100-6**
Complete Filter with
bracket kit, bleeder fitting
and **FLI**[™] gauge



No. **F100-10**
 No. **F100-10B**
Replacement Element,
individually boxed
with "O" ring

Part No.	F100	F100-2	F100-2B	F100-4	F100-6	F100-10	F100-10B
Microns	10	10	15	10	10	10	15
GPH	29	29	29	29	29	29	29
Fuel Oils	1, 2, up to B5	1, 2, up to B5	1, 2, up to B100	1, 2, up to B5	1, 2, up to B5	1, 2, up to B5	1, 2, up to B100

COMMERCIAL - 52 GPH, 20 PSI, 30 Micron, Fuels 1, 2, B5



No. **F100-1**
Complete Filter



No. **F100-3**
Complete Filter with
bracket kit



No. **F100-5**
Complete Filter with
bleeder fitting and **FLI**[™]
gauge



No. **F100-7**
Complete Filter with
bracket kit, bleeder fitting
and **FLI**[™] gauge



No. **F100-11**
Replacement Element,
individually boxed
with "O" ring









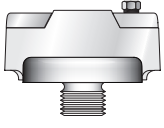

Need help identifying what you need? See cross reference on next page.

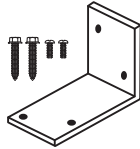
SPIN-ON CROSS REFERENCE - Westwood to others

 No.	Description	Gar-Ber	Sid Harvey (Mitco)	Crown
F99-2	Filter - Residential	-	-	41439
F99-2B	Filter - Residential, w/bracket, 100% Biofuel	-	-	-
F100	Filter - Residential	11V-R	290, 264-SO	-
F100-1	Filter - Commercial	-	292-2, 264-92	-
F100-2	Filter - Residential w/bracket	11BV-R	-	-
F100-2B	Filter - Residential w/bracket, 100% Biofuel	-	-	-
F100-3	Filter - Commercial w/bracket	11BV-M	292-2B, 264-92B	-
F100-4	Filter - Residential w/gauge	11V-RK	-	-
F100-5	Filter - Commercial w/gauge	-	292-2G, 264-92G	-
F100-6	Filter - Residential w/bracket & gauge	11BV-RK	-	-
F100-7	Filter - Commercial w/bracket & gauge	11BV-MK	292-2GB, 264-92GB	-
F100-8	Replacement spin-on filter top only	-	290-SO, 290-SOM	-
F100-10	Spin-On element only - Residential	R	290-6, 264-91	41436
F100-10B	Spin-On element only - Residential, 100% Biofuel	-	-	-
F100-11	Spin-On element only - Commercial	M	292-1, 264-93	-
F100-14	Filter Life Indicator (FLI) color coded gauge, 1/8"-NPT	F.R.I.	-	-

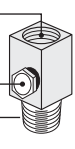
This cross-reference is provided as an aid in identifying which Westwood part numbers most closely replace those part numbers shown. It was accurate at the time it was created, to the extent that the information was publically available. Since manufacturers may sometimes change specs or discontinue products altogether, some inaccuracies may develop over time. Further, the Westwood parts shown will provide an equivalent, or superior, level of performance and service. However, due to differences among manufacturers, physical size and dimensions may vary.

SPIN-ON PARTS & ACCESSORIES

  No. F100-8 Replacement filter top only with holes for bracket	  No. F100-12 Mounting bracket Kit (includes screws)	  No. F100-14 FLI™ (Filter Life Indicator) color coded compound gauge	 1/8"- NPT Standard 8-32 bleed screw with gasket  No. F100-16 Gauge Mount with Bleeder Screw	  No. F100-18 Spin-On filter wrench (fits all popular filters)
--	--	--	---	--



FILTER LIFE INDICATOR GAUGE AND FITTINGS

The **FLI™** gauge is a color coded compound gauge that predicts filter life by showing the running vacuum as the filter loads up. The fittings may also be used as a diagnostic tool wherever a gauge needs to be inserted into the system.

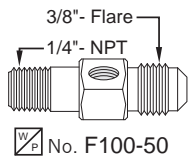
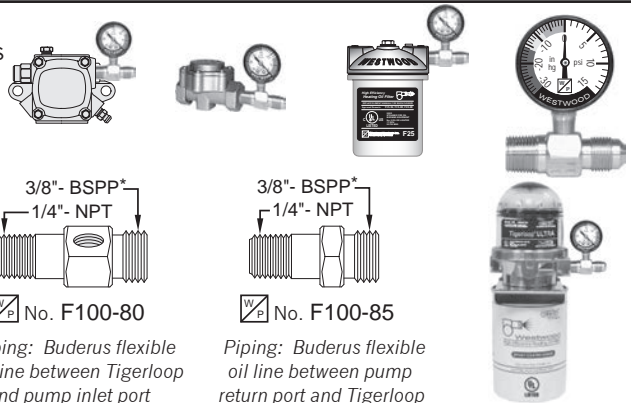

 No. **F100-50**
 Piping: 3/8" Copper
 Use at: Pump, OSV, Tigerloop

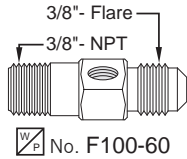

 No. **F100-60**
 Piping: 3/8" Copper
 Use at: Filter

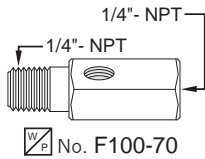

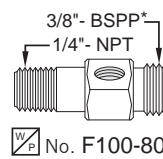

 No. **F100-70**
 Piping: Flexible oil Line
 Use at: Pump, OSV, Tigerloop

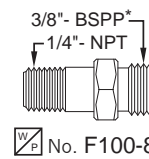

 No. **F100-80**
 Piping: Buderus flexible oil line between Tigerloop and pump inlet port



 No. **F100-85**
 Piping: Buderus flexible oil line between pump return port and Tigerloop

 No.	Description	System Piping	Typically Installed At
F100-14	FLI™ Filter Life Indicator color coded gauge, 1/8"-NPT	-	-
F100-50	FLI™ fitting, 3/8" flare x 1/4"- NPT(M)	3/8" OD Copper	Pump, OSV, Tigerloop
F100-55	F100-50 fitting with FLI™ gauge	3/8" OD Copper	Pump, OSV, Tigerloop
F100-60	FLI™ fitting, 3/8" flare x 3/8"- NPT(M)	3/8" OD Copper	Filter
F100-65	F100-60 fitting with FLI™ gauge	3/8" OD Copper	Filter
F100-70	FLI™ fitting, 1/4"- NPT(F) x 1/4"- NPT(M)	Flexible Oil Line	Pump, OSV, Tigerloop
F100-75	F100-70 fitting with FLI™ gauge	Flexible Oil Line	Pump, OSV, Tigerloop
F100-80	FLI™ fitting, 3/8"- BSPP* x 1/4"- NPT(M), with FLI™ gauge	Buderus Oil Line	Tigerloop to pump
F100-85	Buderus-Tigerloop pump return fitting, 3/8"- BSPP* x 1/4"- NPT(M)	Buderus Oil Line	Pump to Tigerloop

*BSPP = British Standard Pipe Parallel. The thread used on Buderus flexible oil lines.

Please order by  No.

Westwood

SECONDARY FILTRATION ASSEMBLIES

Fully assembled filter assemblies combining Westwood's premium cast iron top filters with Westwood's ultra fine spin-on filter. Connected in series, the **PRIMARY** filter catches most contamination; the **SECONDARY** filter traps the small nozzle plugging particles. All filters used in the secondary filtration assemblies are UL Listed. Service environment: Indoors, 20° to 105° F.

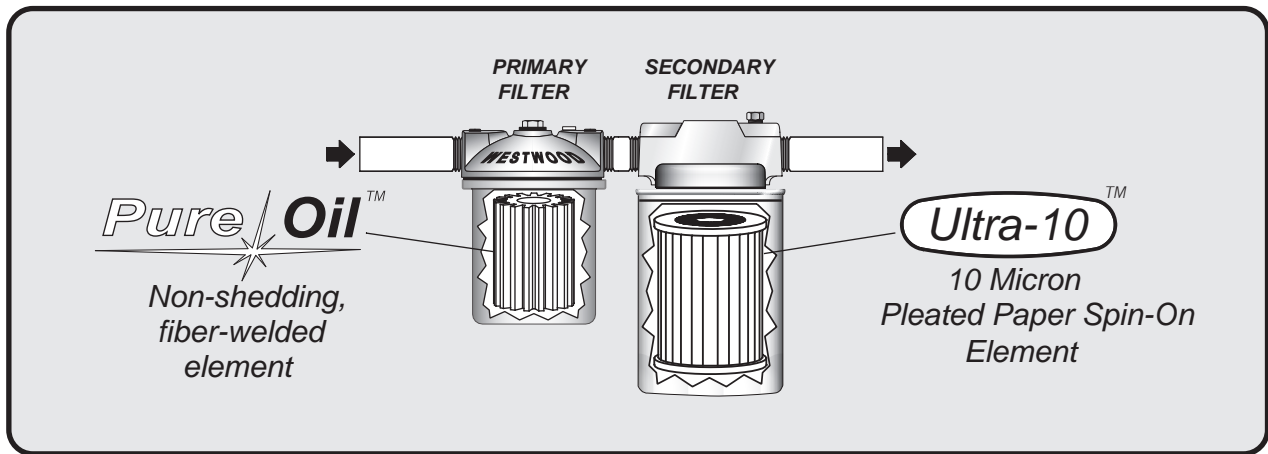

W/P No.	Primary Filter No.	Primary Element	Secondary Filter No.	Secondary Element
F20-100	F20		F100	
F65-100	F65	Pure-Oil™	F100	10 micron spin-on
F80-100	F80		F100	

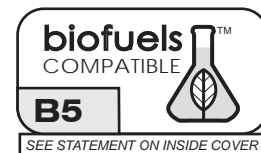

All filters have 3/8" - NPT pipe connections

Take a look ...

UL Recognized CANISTER UPGRADE KITS on page F12
Individual FILTER GASKETS on page F11

F7

Please order by No.

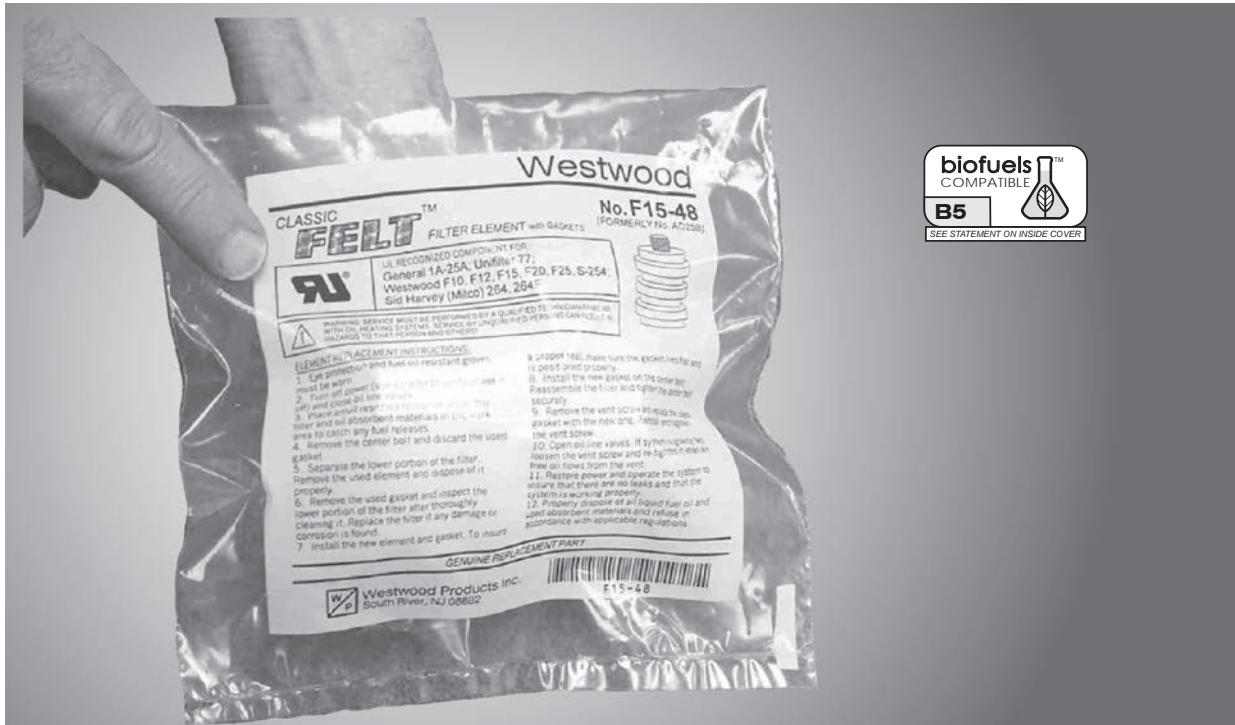

USE ONLY
UL RECOGNIZED
 replacement elements



An industry first! Westwood's new line of replacement filter elements are UL Recognized for use in the General 1A-25A, 2A-700A; Unifilter 77, 99; Sid Harvey (Mico) 264, 265; Fulflo FB4; and Firomatic C-40, C-50

Be Safe! Always look for the UL Recognized Component symbol



Pure Oil™ FILTER ELEMENTS

- ▶ Latest Computer Designed Shape
- ▶ Largest surface area with most filtering ribs
- ▶ Greater capacity - highest in it's class!
- ▶ Fiber-welded for shed free performance
- ▶ Environmentally friendly processed plant fiber
- ▶ Popular elements UL Recognized Components

The Most Advanced Design...
With the Most Advanced Material!

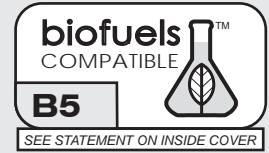
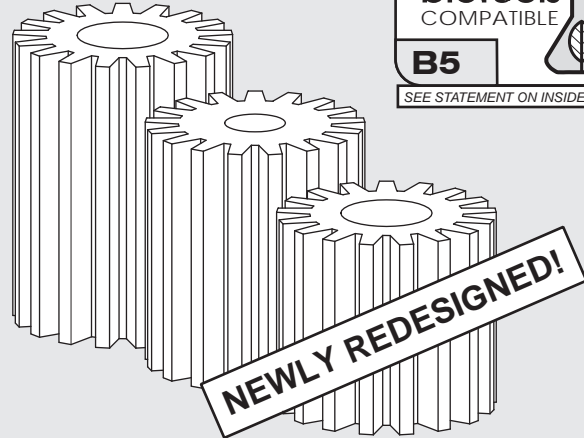

 No.	Reference No.	Description	Fits	QTY PKG
F10-48*	PA-25	Pure-Oil™ Individually bagged with gaskets	General 1A-25A; Unifilter 77; Westwood F10, F12, F15, F20, F25; Sid Harvey (Mitco) 264, 264F	48
F30-24*	-	Pure-Oil™ Individually bagged with gaskets	General 2A-700A; Unifilter 99; Westwood F30, F32, F35, F65, F70; Sid Harvey (Mitco) 265, 265F	24
F80-24*	-	Pure-Oil™ BIG GUY™ Ind. bag w/gaskets	Fulflo FB4; Westwood F80, F84	24
F80-30*	-	Pure-Oil™ bulk packed less gaskets	Fulflo FB4; Westwood F80, F84	30
F80-36*	P4FO-IB	Pure-Oil™ Individually boxed with gaskets	Fulflo FB4; Westwood F80, F84	36
F80-48*	-	Pure-Oil™ Individually bagged with gaskets	Fulflo FB4; Westwood F80, F84	48
F81-10	-	Pure-Oil™ Individually bagged with gaskets	Fulflo FB6	10
F82-6	-	Pure-Oil™ Individually bagged with gaskets	Fulflo FB8	6
F83-4	-	Pure-Oil™ Individually bagged with gaskets	Fulflo FB10	4
F90-6*	-	Pure-Oil™ Individually bagged with gaskets	Firomatic C-40 (RC-20)	6
F90-12*	-	Pure-Oil™ BIG GUY™ Ind. bag w/gaskets	Firomatic C-40 (RC-20)	12
F90-36*	PF-20	Pure-Oil™ Individually bagged with gaskets	Firomatic C-40 (RC-20)	36
F91-6*	-	Pure-Oil™ Individually bagged with gaskets	Firomatic C-50 (RC-30)	6
F91-12*	-	Pure-Oil™ BIG GUY™ Ind. bag w/gaskets	Firomatic C-50 (RC-30)	12
F91-36*	PF-30	Pure-Oil™ Individually bagged with gaskets	Firomatic C-50 (RC-30)	36
F92-6	-	Pure-Oil™ Individually bagged with gaskets	Purolator PF2002	6
F92-36	PP-20	Pure-Oil™ Individually bagged with gaskets	Purolator PF2002	36

* UL Recognized Component



HOLDS TWICE AS MUCH!

Individual FILTER GASKETS on page F11

Ultra-10™

10 MICRON FILTER ELEMENTS

Upgrades any standard filter to the performance of a SPIN-ON!

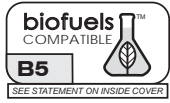

- ▶ 10 Micron rating for super fine filtration
- ▶ Same type element as used in Spin-Ons
- ▶ Advanced collapse-proof design
- ▶ UL Recognized Component

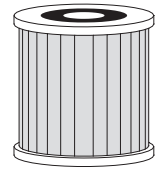
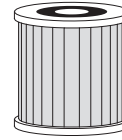

W/P No. **F12-12**

W/P No. **F32-12**

W/P No.	Description	Fits	QTY PKG
F12-12*	Ultra-10™ Indiv. bagged with gaskets	General 1A-25A; Unifilter 77; Westwood F10, F12, F15, F20, F25; Sid Harvey (Mitco) 264, 264F	12
F32-12*	Ultra-10™ Indiv. bagged with gaskets	General 2A-700A; Unifilter 99; Westwood F30, F32, F35, F65, F70; Sid Harvey (Mitco) 265, 265F	12

* UL Recognized Component

CLASSIC



STACKED SEGMENT ELEMENTS

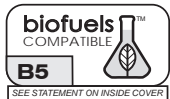

- ▶ Premium quality precision cut wool felt
- ▶ Economical time proven classic design
- ▶ UL Recognized Component

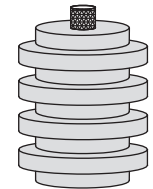
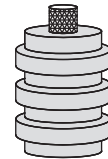

W/P No. **F15-36, -48**

W/P No. **F35-12, -24**

W/P No.	Reference No.	Description	Fits	QTY PKG
F15-36*	A025	CLASSIC FELT™ Indiv. boxed with gaskets	General 1A-25A; Unifilter 77; Westwood F10, F12, F15, F20, F25; Sid Harvey (Mitco) 264, 264F	36
F15-48*	A025B	CLASSIC FELT™ Indiv. bagged with gaskets	Sid Harvey (Mitco) 264, 264F	48
F35-12*	-	CLASSIC FELT™ Indiv. bagged with gaskets	General 2A-700A; Unifilter 99; Westwood F30, F32, F35, F65, F70; Sid Harvey (Mitco) 265, 265F	12
F35-24*	A070	CLASSIC FELT™ Indiv. boxed with gaskets	Sid Harvey (Mitco) 265, 265F	24

* UL Recognized Component

COMMERCIAL ELEMENT™ for General Filters 2A-300

- ▶ Original **Hard to find** sealed can design

W/P No.	Reference No.	Description	Fits	QTY PKG
F75-12	A030	Original sealed can design, individually boxed with gaskets	General 2A-300	12

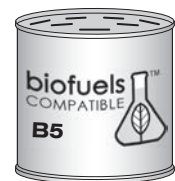

W/P No. **F75-12**

Individual FILTER GASKETS on page F11

Please order by No.

CLASSIC **YARN**™ WOUND ELEMENTS

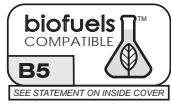

- ▶ Premium quality tightly wound yarn
- ▶ Economical time proven design
- ▶ Popular elements UL Recognized

W/P No.	Reference No.	Description	Fits	QTY PKG
F84-30*	4FO-30	Bulk (no gaskets)	Fulflo FB4;	30
F84-36*	4FO-IB	Boxed with gaskets	Westwood	36
F84-48*	4FO-IBG	Bagged with gaskets	F80, F84	48
F85-10	-	Bagged with gaskets	Fulflo FB6	10
F85-30	6FO-30	Bulk (no gaskets)		30
F86-6	-	Bagged with gaskets	Fulflo FB8	6
F86-30	8FO-30	Bulk (no gaskets)		30
F87-4	-	Bagged with gaskets	Fulflo FB10	4
F87-30	10FO-30	Bulk (no gaskets)		30

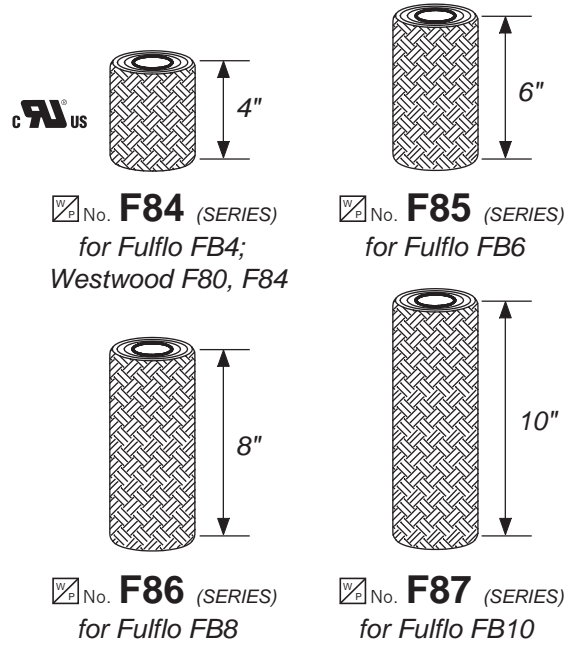

* UL Recognized Component

FUEL FILTER GASKETS

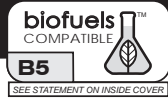

UL Recognized material - Same as used in Westwood's UL Listed filters



W/P No.	Reference No.	Description / Filter Manufacturer and Model Information	Where Used	Material	QTY PKG
F80-60	-	Gasket set for Fulflo FB4, FB6, FB8, FB10; Westwood F80, F84 filters; (1 ea. cover, nut, vent), bagged	Cover Nut Vent	Rubber Fiber Fiber	1 1 1
F10-50	CG-25	General 1A-25A; Unifilter 77;	Cover	Rubber	100
F10-52	BG-25	Westwood F10, F12, F15, F20, F25;	Bolt	Fiber	100
F10-54	-	Sid Harvey (Mitco) 264, 264F	Vent	Fiber	100
F10-55	VG-25	Westwood S-254	Vent	Fiber	100
F30-50	CG-70	General 2A-700A; Unifilter 99;	Cover	Rubber	100
F10-52	BG-25	Westwood F30, F32, F35, F65, F70;	Bolt	Fiber	100
F10-54	-	Sid Harvey (Mitco) 265, 265F	Vent	Fiber	100
F75-50	CG-300	General 2A-300	Cover	Rubber	100
F75-56	LG-300		Lower Can	Rubber	100
F80-50	CG-B4	Fulflo FB4, FB6, FB8, FB10;	Cover	Rubber	100
F80-52	BG-4	Westwood F80, F84	Nut	Fiber	100
F80-54	VG-4		Vent	Fiber	100
F90-50	CG-20	Firomatic C-40 (RC-20), C-50 (RC-30)	Cover	Rubber	100
F90-52	BG-20	DISCONTINUED	Bolt	Fiber	100
F92-50	CG-2002	Purolator PF2002	Cover	Rubber	100
F92-52	BG-2002		Bolt	Rubber	100
F92-54	VG-2002		Vent	Fiber	100

F11



USE ONLY
UL RECOGNIZED
 replacement canisters

Another industry first! Westwood's new line of replacement canisters are UL Recognized for use on General 1A-25A, 2A-700A; Unifilter 77, Unifilter 99; Sid Harvey (Mitco) 264, 264F, 265, 265F; and Fulflo FB4.

Be Safe! Always look for the UL Recognized Component symbol



CANISTER UPGRADE KITS*

Epoxy coated canister, element, center bolt, gasket, fiber washers
 Service environment: Indoors, 20° to 105° F

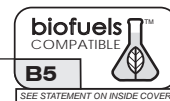

 No.	Element Type	Upgrades
F10-5 F15-5	Pure-Oil™ CLASSIC FELT™	General 1A-25A; Unifilter 77; Westwood F10, F12, F15, F20, F25; Sid Harvey (Mitco) 264, 264F
F30-5 F35-5	Pure-Oil™ CLASSIC FELT™	General 2A-700A; Unifilter 99; Westwood F30, F32, F35, F65, F70; Sid Harvey (Mitco) 265, 265F
F80-5 F84-5	Pure-Oil™ BIG GUY™ CLASSIC YARN™	FULFLO FB4; Westwood F80, F84

* All kits contain UL Recognized Component canisters and elements

Please order by  No.