



UNITED BRASS WORKS, INC.

714 S. Main St. Randleman, N.C. 27317

Tel: 800-334-3035 Fax: 800-498-4696 www.ubw.com



Model 226UT "Y" Blow-Off Valve

Complies with MSS-SP-80-2013

CRN OCO7135.2



200 WSP @ 406° Max • 400 WOG

Non-Shock Service • 100% Pressure Tested

Threaded Ends • Rising Stem • Swivel Disc Holder

PTFE Disc • Integral Seat • Max Pressure for Boiler Blow-Off 160 PSI

Contains Lead. Not Intended for Use in Potable Water Systems

Care must be taken in blow down piping so that no water hammer effect causes shock to the "Y" blow down valve, especially in cases where a boiler has two blow down lines. In such cases both lines should be piped to a common set of blow down valves or each blow off line should be piped separately to the blow down separator. Excessive water hammer or shock can destroy valves and piping and could cause injury.

MATERIAL LIST

NO.	DESCRIPTION	MATERIAL
1	Jam Nut	Steel
2	Hand Wheel	Ductile Iron
3	Stem	Naval Brass
4	Packing Nut	Brass
5	Packing Gland	Brass
6	Packing	NAFG
7	Bonnet	Bronze
8	Bonnet Nut	Bronze
9	Lock Nut	Brass
10	Disc Holder	Brass
11	Body	Bronze
12	Marker Disc	Aluminum

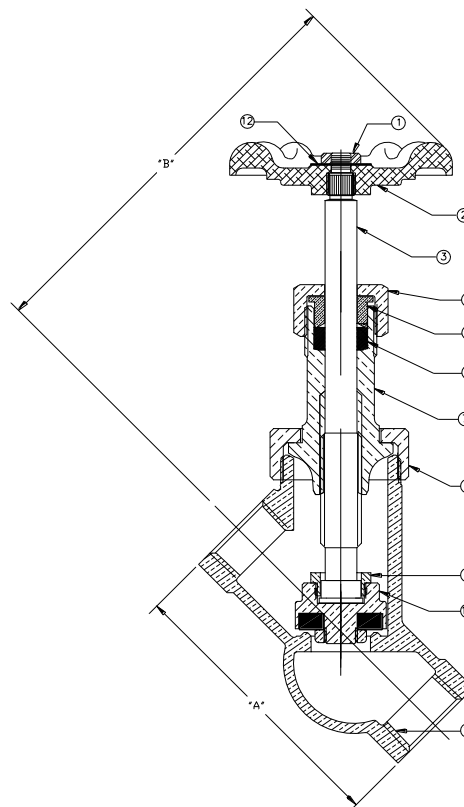

Size	1"	1 ¼"	1 ½"	2"
A	4.75	5.56	6.25	7.75
B	5.75	7.00	7.75	8.75
Ship Wt. (lbs.)	4.20	6.10	9.00	15.00
Qty. Unit Pack	4	4	2	2